

# 365 Gal. (1650 L) Pumping Chamber

## Notes:

1. Concrete: 32 mpa Air 5-7%
  2. Weight: 2200 kgs.
  3. Actual working cap.: 1934 l
  4. Litre per vert. metre: 1465
  5. Maximum cover: 1.5 m
  6. For use in non-sulfate soils
  7. Tank is lifted using external slings.
- Drawing Date: June 25, 2007

**Acton Precast Concrete Limited**  
Acton Ont. 1-800-461-1516

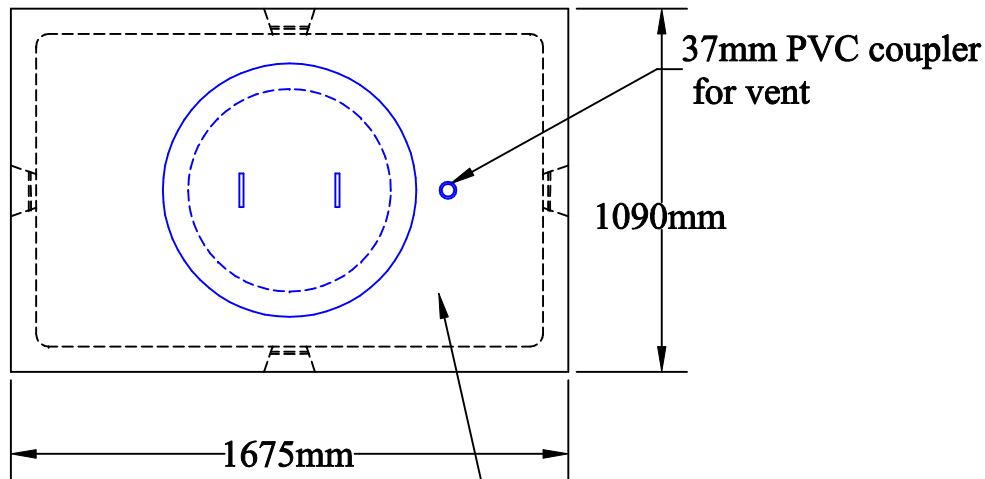

**Top View**

Reinforcing in lid only.  
4 Pcs. 10m bar each way

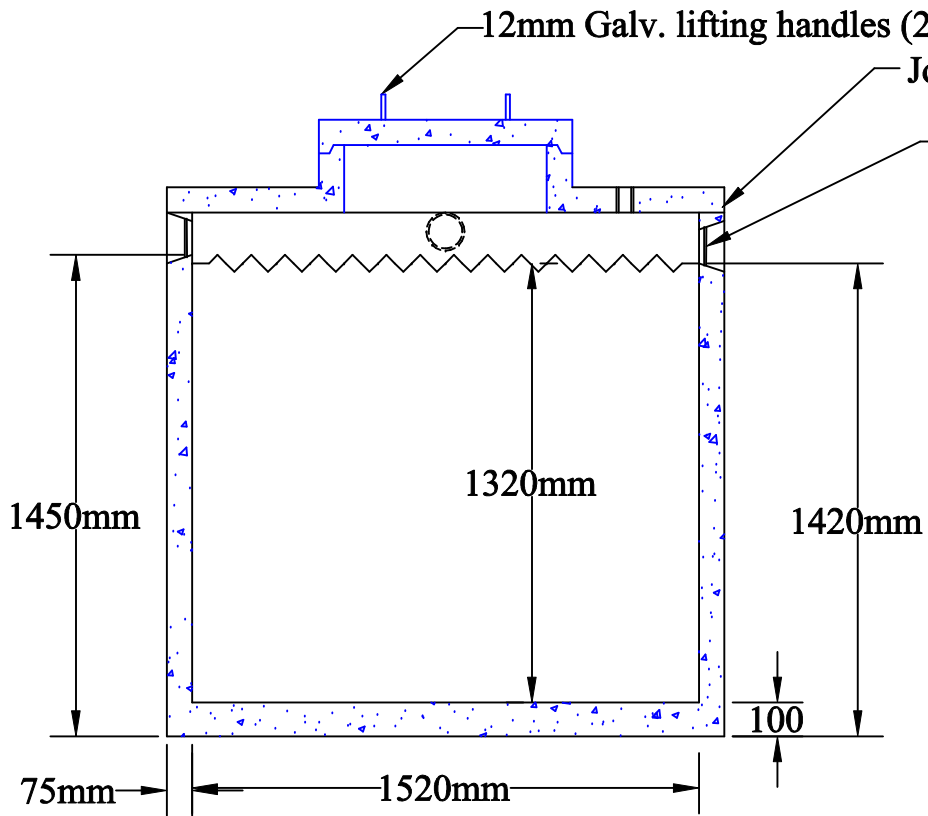

**Section**

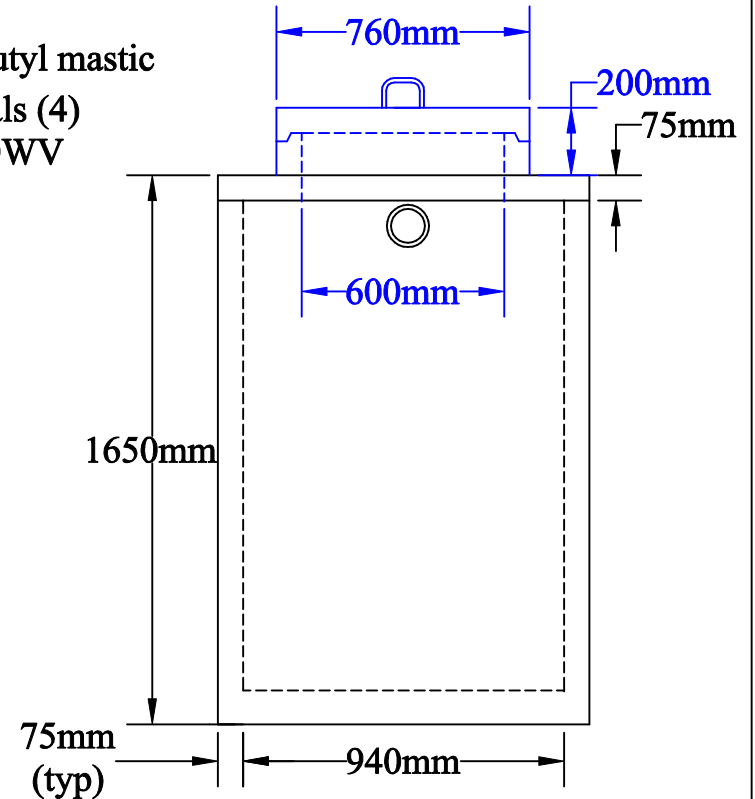

**End View**